

Ontario Energy Board

Northern York Region CDM

Ontario Power Authority Report

May 31, 2007

Michael Lyle, General Counsel
Ontario Power Authority
120 Adelaide St. W., Suite 1600
Toronto, Ontario
M5H 1T1

michael.lyle@powerauthority.on.ca

Direct Line: 416-969-6035

Fax: 416-967-1947

BACKGROUND

In September 2005 the Ontario Power Authority (the “OPA”) submitted a report to the Ontario Energy Board (the “OEB”) recommending a staged electricity plan to meet the needs of Northern York Region (“NYR”). This report was the culmination of several months of extensive study and stakeholder engagement. The OPA adopted a two-phase integrated solution to meet the growing area needs. The first phase was intended to take immediate actions that could address the supply shortfalls in place since 2002. It recommended increasing the amount of static capacitors at Armitage Transformer Station (“TS”) and implementing as much of the planned 20 MW of demand response (“DR”) as possible. It also recommended that construction of a new transformer station at Holland Junction, along with static capacitors at this station, proceed as soon as possible. It was assumed that Holland Junction TS (“HJTS”) could be in-service for summer 2007. The capacitors and DR were implemented for summer 2006, and the Environmental Assessment (“EA”) process for Holland Junction was initiated by Hydro One Networks Inc. (“Hydro One”), following an order from the OEB. The second phase of the plan was expected to provide a solution that could continue meeting the growing needs of NYR. This longer-term phase consisted of roughly 350 MW of simple cycle gas generation and a new transformer station, likely in Aurora. Both were recommended to be in-service by 2011.

On March 26, 2007, the OEB issued letters to parties involved in the NYR supply project – the York Region Distributors (PowerStream, Newmarket Hydro and Hydro One Distribution), Hydro One, and the OPA – requesting information on potential electricity management measures that had been implemented or would be in place for summer 2007, as well as any initiatives that could be expected for 2008 and 2009. The OEB had become aware of potential risks to the in-service date of HJTS, due to delays related to the environmental assessment process. It was identified that the delayed in-service of HJTS may result in inadequate capacity being available from the existing Armitage TS. The OPA was asked to report on conservation and demand management (“CDM”) projects over which it had authority, and the York Region Distributors were collectively asked to comment on the status of all distribution infrastructure projects and CDM initiatives. As well, Hydro One was asked to identify the expected delays in securing environmental permitting, covering best and worst case scenarios. The transmitter was also asked to provide information on any solutions being contemplated to address the identified problem. Each of these parties subsequently filed a report with the OEB as requested.

On April 20, 2007, the OEB then issued a further letter asking the OPA to develop a plan for remedial action to address the potential overloading of Armitage TS for summer 2007, as well as summers 2008 and 2009 because of in-service delays for HJTS. The OEB requested that the OPA coordinate a response from all parties so that operational approaches and any current mitigating measures were identified.

This document is filed in response to the first part of this request – a remedial action plan focusing on mitigation for June to September 2007. A subsequent response will be filed to address the period from 2008 to 2009.

Roles and Responsibilities

All parties involved in developing this report have collaborated to serve the customers of NYR. Planning, implementation and operation of local supply infrastructure is a team-based approach, with each organization having a distinct role and responsibility in order to maintain adequate supply to the area. The Local Distribution Companies (“LDCs”) - Newmarket Hydro, PowerStream, and the distribution group of Hydro One - have a front line role with customers in NYR. They are responsible for distribution facility planning and development, as well as distribution system operation. Essentially, they are accountable for delivering power to the end consumer.

In addition to having full operational and physical control of its transmission and distribution network assets, Hydro One designs, obtains appropriate approvals, implements, and builds transmission facilities in the province. In the specific context of NYR supply and the management of risks associated with overloading of facilities, Hydro One’s role is as follows:

- Specify, design and build transmission connection and transformation facilities;
- Determine equipment capabilities and ratings;
- Monitor the performance and condition of Hydro One assets;
- Maintain, refurbish and replace assets to ensure dependable operation and functionality;
- Establish Pre- and Post-Contingency operational planning and control actions;
- Enable safe operation of its Transmission and Distribution System; and
- Manage customer supply security.

The Independent Electricity System Operator (the “IESO”) is authorized to direct the operation and maintain the reliability of the bulk electricity system in Ontario as well as operating the IESO administered markets. The IESO does not own any electric power generation or transmission facilities. Its responsibilities include operational planning to effectively execute operational instructions and directions for dispatching generation and loads, establishing reliability standards including planning criteria, and monitoring the performance of distribution and transmission facilities connected to the IESO-controlled grid to ensure ongoing reliable supply and delivery of electricity throughout the province.

The OPA is responsible for system and capital planning for the Ontario electricity system, as well as electricity sector development, CDM program development, and resource procurement. Specifically in the planning area, the OPA:

- Forecasts medium- and long-term adequacy and reliability of electricity resources for Ontario;
- Plans for generation, CDM and transmission to meet the needs of consumers;
- Develops integrated power system plans for Ontario; and

- Engages in activities in support of the goal of ensuring adequate, reliable and secure electricity supply and resources in Ontario.

In general, the OPA determines the need for a project, as well as the broad solution and alternatives to meet this need with support from Hydro One, LDCs and the IESO.

PLANNING AND OPERATION

This section describes the standards for system planning and their application in NYR, as well as the operation of the system under normal and contingency situations.

Much of the electricity supply to consumers in NYR, including all of the towns of Newmarket and Aurora, is from Armitage TS located in Newmarket. The peak load recorded for this station last summer was 387 MW, which makes this station one of the larger single supply points in the Ontario electricity system.

Armitage TS is supplied from the transmission system in a standard dual-element spot network (“DESN”) configuration typically used in Ontario for supplying large load centres. The main feature of this configuration is that the loss of a single line or transformer will not interrupt the supply to the customer. The power to the station is obtained from a connection line tapped at Holland Junction in King Township off the main double-circuit 230 kV line, B82/83V, which is between the Claireville station in the City of Vaughan and the Brown Hill station in Georgina. The power is then stepped down from the 230 kV transmission level to the 44 kV distribution level through four large transformers, rated 125 MVA each, at Armitage TS. Sixteen 44 kV distribution feeders emanating from this station supply the customers in the area. The supply arrangement at Armitage TS is shown in Figure 1.

Figure 1: DESN Configuration at Armitage TS

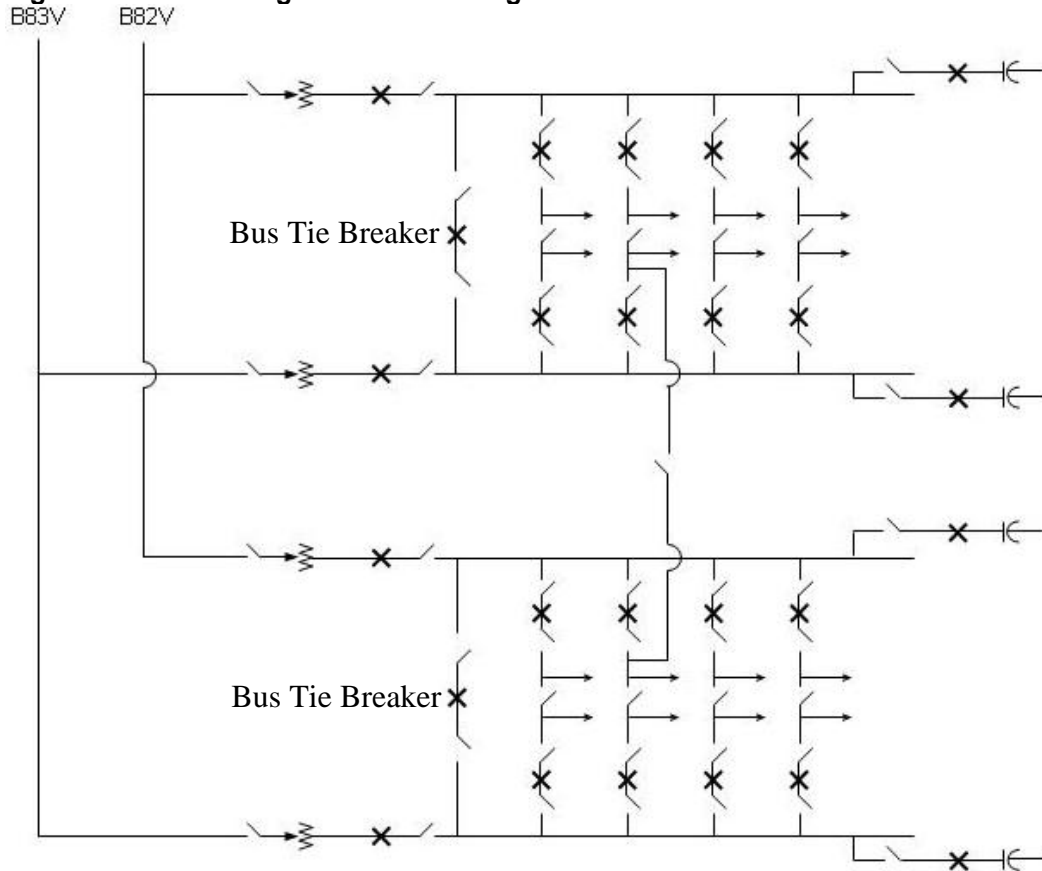

Source: OPA

In assessing the adequacy and reliability of the Armitage supply, it is useful to identify the critical contingencies and supply elements that impact on service availability.

In an electricity network, equipment is subjected to environmental elements and is under high electrical and mechanical stresses. There are many external or internal events that can cause failure at any time. Impactive failure events can occur not only to components at Armitage TS, but also at adjacent stations. Most of these failure events are also of a very rapid rate of transition so that it is not possible for manual intervention either to arrest the failure or to mitigate the resulting impact. Some failures are planned forced outages. In either case, the operational boundaries of the present state of the electricity network must anticipate the possibility and consequence of potential equipment failures and ensure that the state of the network following the failure can be operated safely and reliably.

While the number and combination of equipment or system contingencies are numerous, the contingencies that are considered in typical planning and operational studies for the Armitage type of supply are as follows:

- loss of one of the two 230 kV supply circuits [N-1];

- loss of one of the four step-down transformers [N-1]; and
- loss of the double-circuit 230 kV line [N-2].

The first two are referred to as [N-1] contingency events, and the last is referred to as an [N-2] contingency event. [N-1] contingency events are more probable. They could be the result of lightning strikes, line insulator failures, station equipment failures or protection maloperations. As indicated before, these events are unpredictable and can occur at any time. [N-2] contingency events are less likely and are usually the result of major climatic events such as wind or ice storms, tornadoes, lightning strikes on both circuits on the tower line, or tower structural failures due to mechanical defects or external impacts.

For completeness, the state of the network with all facilities available is also referred to as the [N-0] state.

[N-0] – All Elements In-Service

Normally, because of the redundancy built into the DESN configuration, there is no concern with supply adequacy when all equipment associated with the station supply is available. This is the case with the Armitage supply. Each of the two 230 kV circuits can supply over 400 MVA or over 800 MVA of load in total. The nominal capacity of the four step-down transformers totals 500 MVA. Therefore, although less than desirable voltages may result, Armitage TS can supply a much higher level of load than recorded in the past summers when all equipment is available.

[N-1] Events

In accordance with the IESO's *Ontario Resource and Transmission Assessment Criteria* ("Reliability Criteria"), the standard of service planned for at Armitage TS is to avoid any load interruptions for [N-1] contingencies. The maximum demand that can be supplied in this manner for [N-1] contingencies is termed the firm supply capacity of the station. The planning need date for determining when supply reinforcements will be required at Armitage TS is based on the year when the forecast demand in the area exceeds the firm capacity of the station, with due consideration also for the load restoration need for [N-2] contingencies.

As indicated earlier, with all equipment available, there is no concern about load interruption even if the firm capacity of the station is exceeded. The consideration is the safe and reliable operation of the system following contingency events. The two [N-1] contingency events that are critical to the Armitage supply are: the loss of one of the two 230 kV supply circuits and the loss of one of the four step-down transformers.

Following the loss of one of the 230 kV circuits, B82V or B83V, the associated Claireville, Brown Hill, and Armitage circuit breakers would open, isolating the faulted circuit. This also results in the loss of two transformers connected to that circuit at Armitage TS. With the DESN arrangement, no load is lost as the result of this [N-1] contingency. However, the total station load is now supplied from the remaining 230 kV circuit and the two transformers. Based on

studies conducted by the IESO and the OPA, the 230 kV tap to Armitage has a summer line rating of approximately 490 MVA and this is reached when the Armitage load totals about 440 MW. With the Armitage transformers, Hydro One has determined that its 10 day Long Term Emergency Rating (“LTR”) is 352 MVA and this is reached when the Armitage load totals 340 MW. Additionally, the point at which the steady voltage at Armitage TS is near instability is determined to be about 380 MW.

The other [N-1] contingency of importance is the loss of one of the Armitage transformers. Immediately following its failure, the protection system would open its supply line and the transformer sharing this circuit. This situation is similar to the post-contingency condition following the outage of one of the supply circuits discussed above. However, in this case, the healthy circuit and transformer can be returned to service once the failed transformer is isolated. The supply limitations imposed by the line would not persist and the returned transformer can relieve the remaining pair of transformers by about 40 MW through feeder transfers both inside and outside the station.

These critical load levels for the [N-1] line and transformer outages are summarized in the table below.

Table 1: [N-1] Supply Capability

Limit	MW
Station LTR (10 day)	340
Maximum Voltage Change Limit	340
Station LTR (2 hr)	355
Voltage Stability	380
Station LTR (15 min)	415
Thermal (tap)	440

Source: OPA, IESO, Hydro One

The most restrictive of the limits is the post-contingency loading of the remaining Armitage transformers following an outage to B82V or B83V. This establishes the firm capacity of the station. Should this line contingency occur, the amount of load exceeding the firm capacity limit would have to be interrupted following the contingency.

One means to prevent equipment overloading or a voltage collapse at a DESN station following a critical contingency is to enable automatic load interruptions through the opening of the 44 kV bus-tie circuit breakers. These tie-breakers are installed to maintain continuous supply at DESN supply configured stations for [N-1] contingencies on the transmission system. Bus-tie breakers at Armitage TS can be opened under several scenarios. For example, when the loading is at or beyond 380 MW, it would be opened to respect the voltage instability limit. Alternatively, if the Claireville TS line terminal is open, then the bus-tie breaker could need to be opened at a lower limit, depending on system conditions. When the load at Armitage will necessitate opening the bus-tie breakers to prevent equipment overloading following contingencies, risk of load interruption will be much higher. Any contingency at Armitage TS in this case would automatically result in the interruption to roughly half of the station’s load. The interrupted load

would then be restored to the capacity of the remaining equipment or be transferred to other supply points if such capability exists.

Appendix 1 details Hydro One's standard practices and protocols (subject to changes in real-time) for its controllers in managing the critical contingencies discussed above.

[N-2] Events

In accordance with the Reliability Criteria, the standard of service for planning at Armitage TS is to be able to restore the entire load in a reasonable time for [N-2] contingencies.

With regard to the [N-2] contingency of losing the supply line, the most critical section is between Armitage TS and the tap point at Holland Junction. Other than load that can be transferred to adjacent supply points through the distribution system, there is no supply alternative to Armitage TS should this contingency occur, and load in NYR would be interrupted until the line is repaired. The next most critical section is between the Claireville station and Holland Junction. About 100-150 MW can be supplied from the Brown Hill end-of-the-line once the faulted section is isolated. Rotational load interruptions would occur until the line is repaired. All of the power to Armitage TS can be provided from the Claireville station for the loss of the line north of Holland Junction, after the faulted line section has been isolated. It should be noted that even though the criticality of the Claireville to Holland Junction section is less than the Holland Junction to Armitage section, the exposure is much greater. The former is approximately 33 km in length while the latter is only 8 km.

Distribution Considerations

One final consideration with regard to reliability of supply from Armitage is the lack of additional 44 kV breaker positions at the station to accommodate new distribution feeders and the need to transfer loads to adjacent supply points. This could result in the need to increase loading on existing feeders and possibly to serve load on a feeder with a longer exposure. Even though the unreliability incurred as a result would be related to the distribution system, the attributable cause is due to transmission limitations.

SUPPLY ADEQUACY ANALYSIS

Approach

In order to assess supply adequacy at Armitage TS, the demand at peak was examined under two weather scenarios. The amount of available local resources was then deducted, and the remaining load was compared to the supply capability of the area to determine capacity shortfalls or supply gaps.

Weather Scenarios

In examining the supply adequacy of NYR, two weather scenarios were examined: normal and extreme. Normal weather implies an average day for the season. Thus, for the summer season in NYR, a temperature of approximately 32 degrees Celsius would be assumed. Extreme weather on the other hand, looks at a day where the maximum temperature would be observed. In this case, the temperature would be approximately 35 degrees. Although an area may not regularly reach this extreme weather, many times an area reaches weather conditions very near this scenario. The summers of both 2005 and 2006 reached conditions near the extreme scenario. The system must be able to meet peak demand on the hottest day of the summer, so transmission planning is done for extreme weather. The difference in terms of load between the normal and extreme weather scenarios is roughly 6% or 24 MW for Armitage TS.

Load Forecasts

NYR is a rapidly growing community that has had steadily increasing electricity demand over the last few years, as shown in Table 2. The starting point for both the normal and extreme weather forecasts for 2007 was the actual historical peak. Growth information received from the LDCs was then incorporated to derive the expected total load for the summer of 2007.

Table 2: Historical and Forecast Summer Peak Demand

Entity	2005 Actual (MW)	2006 Actual (MW)	2007 Forecast (MW)	
			Normal Weather	Extreme Weather
Newmarket	150	155	154	163
PowerStream	93	96	94	100
Hydro One Distribution	129	135	135	143
Total Area Demand	372	387	383	406

Source: OPA

Demand Response

Last year, 3 MW of DR was contracted through Rodan Energy and Metering Solutions Inc. (“Rodan”), but the contracted MW reduction was not available in the summer of 2006. This amount will be available for summer 2007, and so it has also been included in this adequacy assessment. However, the 3 MW of contracted DR has not been deducted from the total area demand as presently there is no predictive measure to allow pre-contingency dispatch of the DR. In this case all DR dispatch will take place post-contingency to reduce the amount of load shedding required.

The IESO and Hydro One are, however, investigating viable triggers to dispatch the DR under contract and will attempt to have a communication protocol for Hydro One to request the IESO to dispatch DR for NYR prior to June 15, 2007. In this case, the MW under contract from Rodan would be able to reduce the total area demand in pre-contingency.

Existing Local Generation

Keele Valley is connected to the distribution system at Armitage TS, which means that it nets out the load on the transformers. So, if Keele Valley is running, the demand on the transformers at Armitage will be roughly 19 MW lower than the total load in the area. Generally, when assessing the adequacy of an area, it is assumed that the largest generation unit is out of service. This ensures that supply can still be reliably met while allowing for the situation when a unit suffers a forced outage, is undergoing maintenance, or is not dispatched. This methodology is consistent with Reliability Criteria.

However, in performing an assessment for NYR, Keele Valley had been generating at the time of system peak for the last few summers. As well, the IESO confirmed with the asset owner that the facility is expected to be operating normally this summer. Although it was indicated that the amount of generation was declining due to lower land fill gas volume, 19 MW is expected to be up and running this summer. Therefore, in this risk assessment, Keele Valley generation of 19 MW has been included.

Table 3: Net Area Load

	2005 Actual (MW)	2006 Actual (MW)	2007 Forecast (MW)	
			Normal Weather	Extreme Weather
Total Area Demand	372	387	383	406
Demand Response*	-	-	0	0
Keele Valley Generation	23	22	19	19
Net Area Load	349	365	364	387

* Note the 3 MW of DR is not included here as it is presently a post-contingency measure only
Source: OPA

The Supply Gap

Based on the load forecast for 2007, an assessment of the amount of load at risk was performed. This is an application of the definitions and element outages described in the Planning and Operations section and shown in Table 1.

As shown in Table 4 and Table 5, depending on the contingency, varying amounts of load are at risk. As well, differing amounts of load can be restored following operational measures. It should be noted that when the load is beyond the voltage stability limit, 380 MW, the bus-tie breakers are opened. When the bus-tie breakers are open, any subsequent contingency would result in immediate curtailment of half the station load.

Table 4: Net Demand on Armitage TS for Normal Weather Forecast

Outage	2007 Forecast Net Demand on Armitage TS (Normal Weather) (MW)	Immediately following contingency		Sustained post-contingency operation	
		Capability (MW)	Unsupplied Load (MW)	Capability (MW)	Unsupplied Load (MW)
Transformer Outage	364	380	0	340 + 40	0
Circuit Outage (N-1)		380	0	340	24

Source: OPA

Table 5: Net Demand on Armitage TS for Extreme Weather Forecast

Outage	2007 Forecast Net Demand on Armitage TS (Extreme Weather) (MW)	Immediately following contingency		Sustained post-contingency operation	
		Capability (MW)	Unsupplied Load (MW)	Capability (MW)	Unsupplied Load (MW)
Transformer Outage	387	380	194	340 + 40	7
Circuit Outage (N-1)		380	194	340	47

Source: OPA

The following observations can be drawn for Armitage TS at peak load in the summer of 2007:

- No load is at risk pre-contingency if all facilities are available.
- If one of the transformers at Armitage TS is unavailable, no load will be immediately curtailed for the normal weather scenario. For the extreme weather scenario, half of the station will be lost immediately when the bus-tie breakers are open as each DESN normally supplies about half of the load. This would mean 194 MW would be curtailed. Following controller action, the remaining healthy transformer will be brought back into service as soon as possible so that there are two transformers remaining at one DESN and one transformer at the other DESN. This process may take less than 30 minutes and up to a few hours, depending upon the system conditions and pre-contingency loading. If no load was lost immediately following the contingency, then the load would need to be curtailed down to the 10 day LTR of 340 MW. Roughly 40 MW of load can be switched over to the full DESN, so no load would be left unsupplied at normal weather. If the bus-tie breakers had been opened and load was lost immediately following the contingency, then load could be restored up to the 10 day LTR of 340 MW. Again, 40 MW of load can be transferred over to the full DESN, so only 7 MW would be left unsupplied. As it usually takes about 30 days to replace a failed transformer, any load above the normal transformer rating (approximately 121 MW for each transformer) would need to be curtailed and rotational load shedding would occur after this initial 10 days.
- If an outage is experienced on one of the circuits supplying Armitage TS, no load would be curtailed immediately following a contingency for normal weather. However, for the extreme weather scenario, half of the station load will be lost immediately due to the open bus-tie breakers. Again, this would be roughly 194 MW for the extreme weather scenario. If load was not curtailed following the contingency, as with the normal weather

10/20

Ontario Power Authority

scenario, then load would have to be reduced to the 10 day LTR of the two remaining transformers. This would mean that 24 MW of load was unsupplied. For the extreme weather scenario in which load was lost immediately, load can be restored up to the LTR of the two remaining transformers, or 340 MW. In this case, roughly 47 MW of load would be unsupplied. Rotational load shedding would occur for the amount of load that is not able to be supplied until the circuit is able to be returned to service. Restoration of the outaged circuit may take from less than 30 minutes to a few days depending upon the problem, system conditions and pre-contingency loading.

Risk Exposure Analysis

NYR is a summer peaking area with a very flat peak load profile. As illustrated in Figure 2, the load begins to increase at roughly 7:00 am, levels off around 11:00 am, and doesn't decline until close to 8:00 pm. This means that any measure to be implemented must be able to address the full duration of peak load in order to be effective. For example, if the controllers must open the bus-tie breakers because the load exceeds the voltage stability limit, then they generally will remain open all day until the load begins to decline.

Figure 2: 2006 Peak Day Load Profile

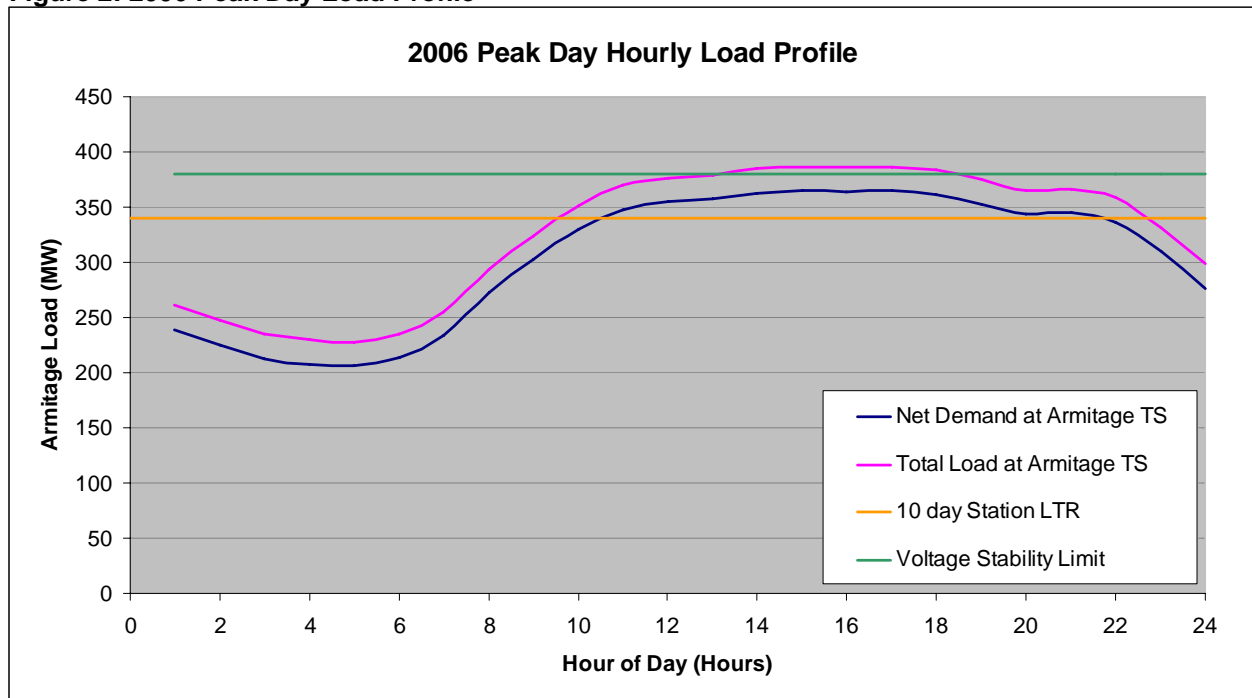

Source: OPA / IESO

The flat characteristic of the load at Armitage TS means that, generally, exposure is not just for a single hour, but rather a full day. An assessment of the forecasted risk exposure was performed for both normal and extreme weather conditions. The load pattern was based on a typical year of hourly load, and then annual load growth was added. Any hour beyond the voltage stability limit or 10 day LTR was then counted as exposed. Table 6 summarizes the number of days where

load is forecast to be above the voltage stability limit of 380 MW, necessitating the opening of the bus-tie breakers. Table 7 indicates the amount of time the load is forecast to be beyond the station LTR of 340 MW.

Table 6: Risk Exposure Analysis – Open Bus Tie Breaker

Exposure	2005	2006	2007 Forecast	
			Normal Weather	Extreme Weather
Days	0	1	0	1
Hours	0	1	0	3

Source: OPA

Table 7: Risk Exposure Analysis – Above Station LTR

Exposure	2005	2006	2007 Forecast	
			Normal Weather	Extreme Weather
Days	18	5	9	25
Hours	76	27	37	140

Source: OPA

It should be noted that if a transformer outage was suffered, then an additional 40 MW of feeder transfer capability is available to increase the supply capability from 340 MW to 380 MW. These feeder transfers are a post-contingency measure though and so do not reduce the number of hours of risk exposure.

Security Analysis

The rare event of an outage to the double-circuit 230 kV supply line to Armitage will interrupt the total station load at Armitage TS. For the loss of the Armitage tap section, the load will not be restored until the line is repaired. Because there is no switching on the line between Claireville TS and Brown Hill TS, for the loss of the section between Claireville and Holland Junction, no load at Armitage TS could be restored until a crew could be sent out to manually isolate the failed line section. This could take several hours. After the faulted line section is isolated, about 150 MW could be restored; the remainder of the Armitage load would be unsupplied until the line is repaired. For failure on the Holland Marsh Junction to Brown Hill TS section, all Armitage TS load would be interrupted until the fault has been isolated, then all load could be restored. The repair time for a major outage of this nature could be up to a week.

THE PLAN FOR REMEDIAL ACTION

In order to help augment the area's supply capability and reduce the risk exposure, several measures are proposed for NYR. These items can be separated into two categories: pre-contingency measures and post-contingency measures. All of the following measures are planned to be implemented in time for this summer.

Pre-Contingency Measures

Maintenance

Hydro One plans to have several stringent maintenance and inspection procedures at Armitage TS. For example, transformer oil testing at Armitage will be on a 6 month cycle rather than the normal 2 year cycle. Plans are also in place to move a spare transformer to the site, which should reduce the time required for replacement if a transformer was to fail.

CDM

There are a number of CDM initiatives under way in York Region. Some of these initiatives are likely to reduce loading on Armitage TS pre-contingency and are addressed in this section. Others will provide relief on a post-contingency basis and are addressed in the subsequent section.

The OPA is once again operating the Every Kilowatt Counts (EKC) and Cool Savings programs for summer 2007 with support from LDCs. The EKC program provides financial incentives to install products such as energy efficient lighting and ceiling fans. The Cool Savings program provides rebates to consumers having their air conditioners tuned by a certified technician. Both of these programs are province-wide and do not have regional targets. The OPA estimates that the peak demand at Armitage could be reduced by roughly 0.5 MW by the end of the summer via these two programs.

The LDCs in NYR are also engaged in several CDM initiatives. Some of these initiatives are funded through distribution rates and others are funded by the OPA. It is the OPA's expectation, based on conversations with LDC staff, that each of the three LDCs will participate fully in the OPA funded LDC CDM programs in the summer of 2007. Extra marketing efforts are also planned in NYR to enhance the effectiveness of the OPA's LDC CDM programs for summer 2007.

The Business Incentive program, funded through the OPA, offers business customers up to \$50,000 in financial incentives for implementing conservation projects. PowerStream expects approximately 0.2 MW of savings from this program in Aurora by late summer. An additional 0.1 MW is anticipated as a result of other distribution rate-funded CDM in the area.

Newmarket Hydro has two industrial retrofit CDM initiatives which are underway. This retrofit program is funded through distribution rates and is projected to provide savings of 0.2 MW. In addition, a target of 0.5 MW has been set for the distribution rate-funded Keep Cool campaign to be achieved by early summer.

Hydro One, PowerStream and Newmarket Hydro jointly participated in the Keep Cool Program in York Region in 2006. Over 400 window air conditioners were retired within Hydro One's territory for a demand reduction of roughly 0.2 MW at Armitage this summer.

Post-Contingency Measures

CDM

Negotiations are underway to secure additional demand response from Rodan. Rodan indicated a capability to provide a further 3 MW of capacity in 2007. While Rodan is confident this is achievable, this capacity will not be available for the entire summer season but will be incremental over the summer. It is expected that capacity will be added each month as follows: 1 MW on July 1, 2007, 1 MW on August 1, 2007 and 1 MW on September 1, 2007. It is anticipated that an amendment to the York DR contract will be in place by early June, which will allow Rodan to bring on as much additional capacity as it is able to, as quickly as possible. The OPA is also exploring the possibility that this contract could be further amended to have Rodan provide up to an additional 10 MW from embedded generation connected to the Armitage TS. If these negotiations are successfully concluded, it may be possible to have this 10 MW in place before the end of the summer.

As with the existing DR from Rodan, there is presently no predictive measure to allow pre-contingency dispatch of the additional DR referred to above. However, IESO and Hydro One are investigating viable triggers to allow DR to be dispatched pre-contingency.

The IESO is continuing to investigate with Emergency Load Reduction Program participants whether they have any load in the NYR. To date, no load has been identified.

PowerStream anticipates a savings of 0.5 MW from its distribution rate-funded enerShift demand response program. This program is designed to reduce demand at peak periods and improve system reliability. Participating customers receive a monthly capacity payment in return for agreeing to reduce their consumption at designated peak demand periods. The OPA-funded PeakSAVER program is a voluntary program that allows LDCs to reduce the electricity being drawn by participating customers' central air conditioning units for brief periods during times of peak demand. This program is expected to contribute savings of roughly 0.3 MW in Aurora by late summer.

Newmarket Hydro's smart thermostat residential load control and critical peak price rebate pilot is expected to yield a peak demand saving of 0.3 MW. This program pilot was funded from distribution rates, but is expected to be fully rolled out with OPA funding. Approximately 1.5 MW of DR capacity is expected by late summer in Newmarket under the PeakSAVER program.

Hydro One estimates that approximately one-third of the CDM initiatives planned for all of York Region will contribute to a reduction in load at Armitage TS, all of which are funded by third tranche. The first phase of Hydro One's residential load control program, Smartstat, was exclusively focused on York Region. Consequently, more than 2,700 customers have been enrolled, which represents approximately 3 MW of load control capacity, or 1 MW of reduction at Armitage. The Double Return program, Hydro One's commercial and industrial demand response initiative, is expected to result in another 0.3 MW of peak demand reduction at Armitage.

14/20

Ontario Power Authority

120 Adelaide Street West, Ste. 1600, Toronto, Ontario M5H 1T1 Tel 416 967-7474 Fax 416 967-1947 1-800-797-9604 Toll Free
info@powerauthority.on.ca www.powerauthority.on.ca

Supply

Newmarket Hydro has explored the feasibility of installing temporary generation at existing distribution substations (DS). However, gas generation requires the availability of higher pressure gas than the typical residential pressure of 60 psi that is available. Four possible sites were examined and the nearest gas line with the required higher pressure is at least one kilometre away from the closest DS. There is insufficient time to extend this pipeline to the DS in time for summer 2007; therefore this is not a feasible solution to address this year's peak.

As noted in the OPA's letter dated April 9, 2007 due to the need for environmental approvals and the time required to install the necessary emissions reduction technology, the use of existing back up diesel generation is also not possible for this summer due to environmental assessment requirements.

Operational Measures

No additional operational measures have been put in place, however roughly 40 MW of existing load transfer between DESNs at Armitage is available.

Capital Plans and New Facilities

PowerStream has completed installation of a 28 kV feeder from Southern York Region into Aurora for emergency use. This new feeder will serve as a backup supply to Aurora when the supply from Armitage is constrained, such as following equipment outages. This feeder will be able to provide 10 MW of additional post-contingency relief, within about 30 minutes.

The Gap – After Remedial Action

After summing the contribution of each of the measures described above, it can be seen that roughly 1.7 MW of relief will be provided pre-contingency for summer 2007 and 26.9 MW post-contingency.

Table 8: Load Forecast After Remedial Action

Measure	2007 Forecast (MW)	
	Normal Weather	Extreme Weather
Net Area Load	364	387
Pre-Contingency Measures:		
CDM (OPA)	0.5	0.5
CDM (PowerStream)	0.3	0.3
CDM (Newmarket)	0.7	0.7
CDM (Hydro One)	0.2	0.2
Total Pre-Contingency Measures:	1.7	1.7
Remaining Area Load	362	385
Post-Contingency Measures:		
Additional DR (Rodan)	3	3
CDM (PowerStream)	0.8	0.8
CDM (Newmarket)	1.8	1.8
CDM (Hydro One)	1.3	1.3
Additional Gas Generation	10	10
Post contingency feeder transfer	10	10
Total Post-Contingency Measures:	26.9	26.9

Source: OPA

This changes the system supply capability for both normal and extreme weather. As indicated in Table 9, no load would go unsupplied following an outage at normal weather with remedial actions in place. At extreme weather, there is still a risk of unsupplied load immediately following a contingency, but it has been reduced to 193 MW, as shown in Table 10. As well, the risk of unsupplied load drops to zero following a transformer outage, and from 47 MW to 18 MW following a circuit outage, due to post-contingency remedial actions.

Table 9: System Supply Capability for Normal Weather Forecast – After Remedial Action

Outage	2007 Forecast Net Demand on Armitage TS (Normal Weather) (MW)	Immediately following contingency		Sustained post-contingency operation	
		Capability (MW)	Unsupplied Load (MW)	Capability (MW)	Unsupplied Load (MW)
Transformer Outage	362	380	0	340 + 40	0
Circuit Outage (N-1)		380	0	340	0

Source: OPA

Table 10: System Supply Capability for Extreme Weather Forecast – After Remedial Action

Outage	2007 Forecast Net Demand on Armitage TS (Extreme Weather) (MW)	Immediately following contingency		Sustained post-contingency operation	
		Capability (MW)	Unsupplied Load (MW)	Capability (MW)	Unsupplied Load (MW)
Transformer Outage	385	380	193	340 + 40	0
Circuit Outage (N-1)		380	193	340	18

Source: OPA

Risk Exposure Analysis

The risk exposure for opening the bus-tie breaker remains unchanged with these measures, but the number of days above station LTR is slightly reduced with remedial action. Post-contingency measures do not reduce the risk exposure, but will decrease the amount of unsupplied load.

Table 11: Risk Exposure Analysis – Open Bus Tie Breaker after Remedial Action

Exposure	2005	2006	2007 Forecast		2007 with Remedial Action	
			Normal Weather	Extreme Weather	Normal Weather	Extreme Weather
Days	0	1	0	1	0	1
Hours	0	1	0	3	0	3

Source: OPA

Table 12: Risk Exposure Analysis – Above Station LTR after Remedial Action

Exposure	2005	2006	2007 Forecast		2007 with Remedial Action	
			Normal Weather	Extreme Weather	Normal Weather	Extreme Weather
Days	18	5	9	25	8	23
Hours	76	27	37	140	32	128

Source: OPA

CONCLUSION

There is an urgent need to continue to provide relief for NYR. Additional infrastructure is required in order to maintain an adequate and reliable electricity supply in the area. Without additional electricity infrastructure, operating measures are required and the level of service to customers is degraded. The amount of load interrupted by a single contingency in NYR is higher than that recommended in the Reliability Criteria for large stations such as Armitage. Although a significant amount of load could be interrupted for a single contingency in the area this summer, most load can be restored within a short time period. Based on the relief to be provided by the measures described above, the risk to NYR supply should be manageable this summer.

ACKNOWLEDGMENTS

The OPA wishes to express its appreciation for the cooperation received from Newmarket Hydro, PowerStream, Hydro One, and the IESO in preparing this document.

17/20

Ontario Power Authority

120 Adelaide Street West, Ste. 1600, Toronto, Ontario M5H 1T1 Tel 416 967-7474 Fax 416 967-1947 1-800-797-9604 Toll Free info@powerauthority.on.ca www.powerauthority.on.ca

APPENDIX 1

Operating Protocols – Armitage TS

These operating protocols are consistent with and based upon Hydro One's standard operating practices.

ARMITAGE TS PEAK LOADING

Assumptions based on peak loading - August 1, 2006 @ 31 degrees C.

T1/T2 Peak 213 MVA

T3/T4 Peak 229 MVA (Keele Valley NUG (22 MW) O/S)

207 MVA (Keele Valley NUG (22 MW) I/S)

KEY ARMITAGE TS LTRs @ 31 degrees C.

15 minute rating for bus work 215 MVA (**LIMITING COMPONENT**)

15 minute rating* for transformer T1 258 MVA

15 minute rating* for transformer T2 258 MVA

15 minute rating* for transformer T3 243 MVA

15 minute rating* for transformer T4 256 MVA

*NOTE: above ratings based on full cooling with no equipment degradation.

Normal Operation

Normal transformer loading is limited to the continuous rating of each transformer. When the load exceeds the continuous rating all efforts are made to transfer load in order to get back to the continuous rating.

During planned maintenance activities or emergency conditions, transformers may be loaded to Limited Time Ratings ("LTR") for the period specified for that rating. By the end of that period, load must be transferred or shed in order to reduce the transformer loading to the applicable rating.

Emergency Situations

On the loss of a Transformer at either of the Armitage DESN transformer stations, the load on the remaining in service transformer bank must respect the LTR. Since under the normal operating conditions noted above the transformers should not exceed the continuous rating per transformer, the LTRs are used as an emergency measure to allow time to reduce load before the shedding of primary load is required.

- If the load on the remaining transformer bank were to be above the 10 day LTR, but within the 2-hour LTR rating, the OGCC Controller would have 2 hours to reduce load to

18/20

Ontario Power Authority

120 Adelaide Street West, Ste. 1600, Toronto, Ontario M5H 1T1 Tel 416 967-7474 Fax 416 967-1947 1-800-797-9604 Toll Free
info@powerauthority.on.ca www.powerauthority.on.ca

the 10 day LTR. Any load still exceeding the 10 day transformer rating after the 2 hours would be cut immediately.

- If the load on the remaining transformer bank were to be above the 10 day LTR, but within the 15 minute LTR rating, the OGCC Controller would have 15 minutes to reduce load to the 10 day LTR. Any load exceeding the 10 day transformer rating after the 15 minutes would be cut immediately.
- If the load post contingency were to exceed the 15 minute BUS LTR, action such as splitting the bus will not be taken pre-contingency.
- If the load post contingency were to exceed the 15 minute TRANSFORMER LTR, action such as splitting the bus will be taken pre-contingency to protect the transformer.

The Hydro One OGCC Controllers would work with the customers to transfer load off of the remaining transformer bank to respect the LTRs limits noted above during the time frames available. However if these ratings cannot be respected, load cuts (interruptions) would be implemented. The initial feeder selection would be at the discretion of the on shift Controller unless documented direction is in place. After the initial load has been cut to respect the applicable LTR limits –

- The Controller would go into a 30 or 60 minute rotational load shedding process.
- At this point all customers will share the burden for load shedding.
- Critical loads can be exempted from the rotational load shedding process.
- Hydro One will be working with the customers to identify which loads should and should not be included in the rotational load shedding selection.

On the loss of a Transmission Line the same limits noted above apply. However it should be noted that the loss of a Transmission line (B82V or B83V) will affect one transformer at each of the Armitage DESN transformer stations. Accordingly, load transfer capabilities between the 2 DESNs may be restricted.

The voltage stability limit of 380 MW is the most limiting factor and will initiate opening of the bus-tie breaker.

The following tables illustrate the various levels of operator intervention for the DESN transformer stations at Armitage.

Armitage T1 & T2
Pre Contingency (all elements in service)

Load level (MVA)	Operator Action	Result
Prior to reaching 183 MVA 10 day rating	OGCC will contact the LDCs to advise that loading is approaching the 10 day LTR (post contingency)	Evaluate the station loading profile and initiate load transfers.
Above 183 MVA 2 hour rating Note: The limiting component is the bus	OGCC advises LDC that the total station is over the 10 day LTR (post contingency)	Controllers know that if a contingency occurs, they will be running in a 2 hour or less LTR and that they have 2 hours or less to get loading back to 10 day ratings.
Above 215 MVA 15 minute rating Note: The limiting component is the bus	Shed load (immediately upon contingency) to respect 10 day LTR	Controllers know that if a contingency occurs limiting component failure is imminent. 15 minute rating of remaining TRANSFORMER - 258 MVA must never be exceeded

Armitage T3 & T4
Pre Contingency (all elements in service)

Load Level (MVA)	Operator Action	Result
Prior to reaching 167 MVA 10 day rating	OGCC will contact the LDCs to advise that loading is approaching the 10 day LTR (post contingency)	Evaluate the station loading profile and initiate load transfers.
Above 183 MVA 2 hour rating Note: The limiting component is the bus	OGCC advises LDC that the total station is over the 10 day LTR (post contingency)	Controllers know that if a contingency occurs, they will be running in a 2 hour or less LTR and that they have 2 hours or less to get loading back to 10 day ratings.
Above 215 MVA 15 minute Rating Note: The limiting component is the bus	Shed load (immediately upon contingency) to respect 10 day LTR	Controllers know that if a contingency occurs limiting component failure is imminent. 15 minute rating of remaining TRANSFORMER (T3 – 243 MVA or T4 - 256 MVA) must never be exceeded