



BY E-MAIL AND WEB POSTING

NOTICE OF PROPOSAL TO AMEND A CODE

PROPOSED AMENDMENTS TO THE DISTRIBUTION SYSTEM CODE

BOARD FILE NUMBER: EB-2007-0709

To: All Licensed Electricity Distributors
All Participants in Consultation Process EB-2007-0709

The Ontario Energy Board (the "Board") is giving notice under section 70.2 of the *Ontario Energy Board Act, 1998* (the "Act") of its proposal to amend the Distribution System Code (the "Code").

Background

In relation to its consultation on farm stray voltage, the Board issued a Notice of Proposal to Amend a Code on October 31, 2008 (the "October Notice"). In the October Notice, the Board proposed a number of changes to the Distribution System Code the purpose of which is to establish standards and procedures designed to meet the objective of ensuring that electricity service to farm customers, in relation to 'tingle' or 'stray' voltage, is of a quality that does not unduly impact the operation of the farm.

The Notice also indicated that, in addition to the proposed Code amendments issued at that time, it was the Board's intention to prescribe an investigation procedure, to be included as Appendix H to the Code, which permits the accurate determination of the contribution from the distribution system to total measured farm stray voltage at animal contact locations. The Board is now proposing that the Code be amended to include that distributor investigation procedure as

Appendix H to the Code. The text of the proposed Appendix H is set out in Appendix A to this Notice. The Board acknowledges the extensive contribution of the Electrical Safety Authority in the preparation of the proposed distributor investigation procedure.

Note on the Proposed Amendments

To ensure the consistent application of a uniform approach for all distributor farm stray voltage investigations, the proposed distributor investigation procedure refers exclusively to measurements of animal contact voltage (ACV). ACV values, measured as prescribed in the proposed distributor investigation procedure, will represent accurately the equivalent values for animal contact current (ACC) when converted using Ohm's law (current = voltage/resistance).

Anticipated Costs and Benefits of the Proposed Amendments

The anticipated costs and benefits of the proposed amendments to the Code pertaining to farm stray voltage were set out in the October Notice and interested parties should refer to the October Notice for further information in that regard. The Board believes that codification of the proposed distributor investigation procedure will add somewhat to the cost of distributor farm stray voltage investigations but that these incremental costs will be offset by savings related to avoided re-testing associated with disputed test procedures and results. Therefore, the Board believes that distributor costs will not be affected in a material way relative to the costs referred to in the October Notice.

Coming into Force

The Board recognizes that distributors will require some time to bring their practices into line with the proposed distributor investigation procedure. The Board therefore proposes that the Amendments to the Code as set out in Appendix A come into force 90 days from the date on which they are published on the Board's website after having been made by the Board.

Cost Awards

Cost awards will be available to eligible persons under section 30 of the *Ontario Energy Board Act, 1998* in relation to the provision of comments on the proposed Amendments set out in Appendix A **to a maximum total of 15 hours**. All participants determined to be eligible in the Board's Decision on Cost Eligibility dated October 11, 2007 and its Supplementary Decision on Cost Eligibility dated November 29, 2007 are eligible for an award of costs in relation to this notice and comment process.

Costs awarded will be recovered from all licensed electricity distributors based on their respective distribution revenues, with the exception of the following distributors that have identified themselves to the Board as not having farm customers:

E.L.K. Energy Inc.

EnWin Utilities Limited

Orillia Power

PowerStream Inc.

Toronto Hydro

Woodstock Hydro Services Inc.

Invitation to Comment

All interested parties are invited to submit written comments on the proposed Amendments by **April 30, 2009**. Three (3) paper copies of each filing must be provided, and should be sent to:

Kirsten Walli
Board Secretary
Ontario Energy Board
P.O. Box 2319
2300 Yonge Street
Suite 2700
Toronto ON M4P 1E4

The Board requests that interested parties make every effort to provide electronic copies of their filings in searchable/unrestricted Adobe Acrobat (PDF) format. The Board also requests that interested parties submit their filings through the Board's web portal at www.errr.oeb.gov.on.ca. A user ID is required to submit documents through the Board's web portal. If you do not have a user ID, please

fill out a user ID password request which can be obtained by visiting the “e-filings services” webpage on the Board’s website at www.oeb.gov.on.ca. Additionally, interested parties are requested to follow the document naming conventions and document submission standards outlined in the document entitled “RESS Document Preparation – A Quick Guide” also found on the “e-filing services” webpage. If the Board’s web portal is not available, electronic copies of filings may be filed by e-mail at boardsec@oeb.gov.on.ca.

Those that do not have internet access should provide a CD or diskette containing their filing in PDF format.

Filings to the Board must be received by the Board Secretary by **4:45 p.m.** on the required date. They must quote file number EB-2007-0709 and include the name, address, telephone number and, where available, e-mail address and fax number of the sender.

This Notice, including the attached proposed amendments to the Code and all written comments received by the Board in response to this Notice, will be available for public viewing on the Board’s web site at www.oeb.gov.on.ca and at the office of the Board during normal business hours.

If you have any questions regarding the proposed amendments described in this Notice, please contact Stephen Cain at stephen.cain@oeb.gov.on.ca or at 416-440-8144. The Board’s toll free number is 1-888-632-6273.

DATED at Toronto, March 31, 2009.

ONTARIO ENERGY BOARD

Original Signed By

John Pickernell
Assistant Board Secretary

Appendix:A - Proposed Amendments to the Distribution System Code

Appendix A

To Notice Dated March 31, 2009

Proposed Amendments to the Distribution System Code

1. Section 1.7 of the Distribution System Code is amended by adding the following immediately after the last paragraph of that section:

Appendix H, made by the Board on [insert date], comes into force on the day that is 90 days after the date on which they are published on the Board's website after having been made by the Board.

2. The Distribution System Code is amended by adding the attached Appendix H immediately after Appendix G.

APPENDIX H

Farm Stray Voltage Distributor Investigation Procedure

APPENDIX H
FARM STRAY VOLTAGE DISTRIBUTOR INVESTIGATION PROCEDURE

THIS PAGE INTENTIONALLY BLANK

APPENDIX H
FARM STRAY VOLTAGE DISTRIBUTOR INVESTIGATION PROCEDURE

TABLE OF CONTENTS

Glossary of Symbols	4
H.1 APPLICATION AND SCOPE	5
H.2 DEFINITIONS	5
H.3 SAFETY	6
H.4 EQUIPMENT AND OTHER REQUIREMENTS	7
H.4.1 Measuring and Recording Devices.....	7
H.4.2 Load Box	8
H.4.3 Other Equipment	8
H.4.4 Test Scheduling.....	9
H.4.5 Investigation Sequence	9
H.4.6 Documentation	9
H.4.7 Investigation Report	10
H.5 INVESTIGATION PROCEDURE	10
H.5.1 Phase 1 Procedure.....	10
H.5.1.1 Animal Contact Test.....	10
H.5.1.2 Farm Stray Voltage Test	12
H.5.2 Phase 2 Procedure.....	14
H.5.2.1 Distributor Contribution Test.....	14
H.5.2.2 Distributor Contribution Calculations	16
H.5.3 Phase 3 Procedure.....	17
H.5.3.1 Distributor Contribution Confirmation Test & Calculations.....	17
H.5.3.2 Final Farm Stray Voltage Test.....	17

FORMS

Form 1	Animal Contact Test
Form 2	Farm Stray Voltage Test
Form 3	Distributor Contribution Test Data
Form 4	Distributor Contribution Calculations
Form 5	Distributor Contribution Confirmation Test & Calculations
Form 6	Final Farm Stray Voltage Test

APPENDIX H
FARM STRAY VOLTAGE DISTRIBUTOR INVESTIGATION PROCEDURE

GLOSSARY OF SYMBOLS

I_{LB}	load box current
I_p	transformer primary current (on the source side of the ground connection)
R_{source}	source resistance
V_{cc}	animal contact voltage (measured across a 500 Ohm shunt resistor) between two animal contact points
V_{ccD}	distributor contribution to animal contact voltage
$V_{cc_{fsv}}$	highest steady state value of animal contact voltage measured during the Farm Stray Voltage Test
$V_{cc_{full}}$	animal contact voltage during the Distributor Contribution Test measured with the farm power “off” and the load box set at maximum load
$V_{cc_{half}}$	animal contact voltage during the Distributor Contribution Test measured with the farm power “off” and the load box set at one-half load
$V_{cc_{off}}$	animal contact voltage during the Distributor Contribution Test measured with the farm power “off” and the load box “off”
V_{LB}	voltage at load box connection to secondary system
V_{oc}	open circuit voltage (measured without a shunt resistor) between two animal contact points
V_p	voltage from the primary neutral at the transformer to a reference ground rod
$V_{p_{fsv}}$	value for the primary neutral to reference ground rod voltage corresponding to the highest measured steady state value of animal contact voltage measured during the Farm Stray Voltage Test ($V_{cc_{fsv}}$)
$V_{p_{full}}$	value of the primary neutral to reference ground rod voltage measured during the Distributor Contribution Test with the farm power “off” and the load box set at maximum load
$V_{p_{half}}$	value of the primary neutral to reference ground rod voltage measured during the Distributor Contribution Test with the farm power “off” and the load box set at one-half load
$V_{p_{off}}$	value of the primary neutral to reference ground rod voltage measured during the Distributor Contribution Test with the farm power “off” and the load box “off”
V_{pri}	nominal primary phase conductor voltage to neutral conductor voltage
V_{ps}	voltage drop from the primary neutral conductor at the location of the connection for V_p to the secondary neutral conductor at the location of the connection for V_s
V_s	voltage from the secondary neutral in the service panel serving the animal contact area to the reference ground rod

APPENDIX H
FARM STRAY VOLTAGE DISTRIBUTOR INVESTIGATION PROCEDURE

H.1 APPLICATION AND SCOPE

This investigation procedure shall be followed by distributors in accordance with section 4.7 of the Code. This investigation procedure focuses on the measurement of farm stray voltage at animal contact locations and on the measurement of contributions to ACC/ACV from the distributor's distribution system.

A distributor shall ensure that any investigator acting on the distributor's behalf in conducting an investigation under section 4.7 of the Code and this Appendix complies with all of the requirements of this Appendix.

H.2 DEFINITIONS

In this Appendix:

"ACC/ACV Threshold" means the ACC or ACV value specified in section 4.7.3 of the Code;

"Animal Contact Test" means the test described in section H.5.1.1;

"animal contact point" means an object or surface an animal can contact physically, such as the pavement, a metal stall stanchion, a metal object in a barn or milking parlour, a water bowl or trough or earth;

"animal contact location" means a location where an animal can contact two animal contact points at the same time;

"current" means Alternating Current current, root mean square;

"Distributor Contribution Test" means the test described in section H.5.2.1;

"Distributor Contribution Calculations" means the procedure described in section H.5.2.2;

"Distributor Contribution Confirmation Test & Calculations" means the test and procedure described in section H.5.3.1;

"Distributor Contribution Threshold" means the contribution by a distribution system to ACC or ACV as specified in section 4.7.4 of the Code;

"Farm Stray Voltage Test" means the test described in section H.5.1.2;

"Final Farm Stray Voltage Test" means the test described in section H.5.3.2.

APPENDIX H

FARM STRAY VOLTAGE DISTRIBUTOR INVESTIGATION PROCEDURE

“investigator” means a person responsible for investigating, analyzing and determining the appropriate means of remediating farm stray voltage situations on a distributor’s behalf for the purposes of meeting the distributor’s obligations under section 4.7 of the Code;

“resistance” means the property of hindering the flow of current in an electric circuit;

“root mean square” (“rms”) means the square root of the arithmetic mean (i.e., the average) of the squares of a set of values;

“shunt resistor” means a physical resistor (or combination of resistors) used to simulate the combined resistance of an animal’s body and the resistance between the animal’s body and the animal contact points;

“source resistance” means the resistance in a circuit excluding the combined resistance of the animal’s body and the resistance between the animal’s body and the animal contact points;

“steady state” means the value of a voltage after all transients have decayed to a negligible value. For an alternating quantity, the root-mean-square value in the steady state does not vary with time; and

“voltage” means Alternating Current voltage, root mean square.

H.3 SAFETY

- (1) A distributor shall ensure that the investigation procedures set out in this Appendix are executed by persons qualified under the *Occupational Health and Safety Act* (Ontario).
- (2) If an investigator reasonably believes that a significant or immediate safety hazard is posed by conditions at the site of an investigation, the investigator may suspend the execution of the investigation procedure until the hazard is rectified. The investigator shall promptly report any hazard to life or property to the Electrical Safety Authority.
- (3) An investigator may suspend testing if the presence of animals, in any area where electrical equipment or wiring is examined or electrical measurements are taken, creates a potential hazard to the distributor’s personnel.
- (4) An investigator shall identify and note the locations of electric fences and other electrified animal control devices in accordance with section H.4.6(1).

APPENDIX H
FARM STRAY VOLTAGE DISTRIBUTOR INVESTIGATION PROCEDURE

H.4 EQUIPMENT AND OTHER REQUIREMENTS

H.4.1 Measuring and Recording Devices

An investigator shall ensure that equipment used for the measurement and/or recording of voltage, current, and resistance meets the criteria specified below:

- (1) **Resolution and Accuracy** - The accuracy and resolution of any instrument used to measure or record animal contact voltage shall limit the error to five percent or less at one volt .
- (2) **Voltage Measurement** - Instruments used to measure animal contact voltage shall be capable of separating and independently measuring alternating current (AC) and direct current (DC) voltages. These instruments shall have a minimum internal impedance of ten thousand Ohms and shall measure the true voltage.
- (3) **Current Measurement** - A clamp-on ammeter, a digital multi-meter with clamp-on device or an in-line ammeter shall be used to measure current. Such instruments shall meet the resolution and accuracy requirements specified in section H.4.1(1), shall be capable of separating and independently measuring alternating current (AC) and direct current (DC) and shall measure the true current.
- (4) **Resistance Measurement** – The resistance of a resistor shall be measured using either a volt ohmmeter or a digital multi-meter. Resolution shall be to the level of one Ohm or less when measuring a resistance of less than one thousand Ohms. Accuracy shall be within plus or minus five Ohms for a five hundred Ohm resistance.
- (5) **Calibration of Measuring Instruments** - All measuring instruments shall be calibrated as to resolution and accuracy annually or according to the manufacturer's recommended calibration schedule, whichever is more frequent. Calibration certification shall be obtained from either:
 - a) the instrument manufacturer; or
 - b) a laboratory currently certified as meeting all applicable Institute of Electrical and Electronic Engineers, International Organization for Standards standards, or other recognized standards.
- (6) **Field Check** - Before each site investigation, measuring devices shall be field-checked by comparing measurements with those taken using a second calibrated instrument.
- (7) **Digital Recording Devices** - Recording devices, including monitoring systems which combine measuring and recording functions in a single instrument, shall have the levels of resolution and accuracy described under section H.4.1(1), shall have averaging capability and shall be capable of storing data recorded over measurement intervals of one to ten seconds for up to seventy-two consecutive hours. Digital recording devices, which have deviation settings, shall permit the deviation setting to be set so as to meet these resolution, accuracy

APPENDIX H

FARM STRAY VOLTAGE DISTRIBUTOR INVESTIGATION PROCEDURE

and capability requirements. Digital recording devices shall be able to log the time and date of all data recorded and shall have their internal clocks synchronized.

H.4.2 Load Box

An investigator shall ensure that the load box meets the criteria specified below:

- (1) Volts - A load box shall be a primarily non-inductive nominal two hundred forty volt, resistance heating type load.
- (2) Power - Testing shall be accomplished with a dual element 9/18 or 12.5/25 kW load box.
- (3) Split-Load - A load box shall be capable of operating at two or more load settings, including approximately fifty percent and one hundred percent of the load box's rated total load.

H.4.3 Other Equipment

An investigator shall use the following equipment, as required, in conducting an investigation under this Appendix:

- (1) A steel portable ground rod at least 1.0 m in length and 1.5 cm in diameter, sharpened at one end to ease insertion into the earth. The rod must be equipped with a terminal that permits a stainless steel hose clamp or alligator clip to be connected to the rod and must be marked at a point 50 cm from the sharpened rod end (the target depth of insertion).
- (2) Three 50 m reels of insulated #14, #16 or #18 stranded wire. Equip one end of each roll of wire with a stainless steel hose clamp or an alligator clip of suitable size to connect to the ground rod. Equip the other end with a banana plug capable of connecting to the measuring instruments used.
- (3) A copper plate with a regular shape (square, rectangular or round) and a base area measuring at least 100 cm². The plate must be clean prior to each use.
- (4) One weight of at least 10 kg (used in combination with the copper plate referred to in (3) above).
- (5) Wire brush.
- (6) Paper towels.
- (7) Salt water solution.
- (8) Pocket calculator.
- (9) One five hundred Ohm (+/- 2%) shunt resistor or equivalent combination of resistors.
- (10) Two ten thousand Ohm (+/- 2%) shunt resistors or equivalent combination of resistors.

APPENDIX H

FARM STRAY VOLTAGE DISTRIBUTOR INVESTIGATION PROCEDURE

H.4.4 Test Scheduling

An investigator shall schedule any tests, both as to time and duration, in consultation with the livestock farm customer to ensure that the test time and/or other conditions are consistent with those during or in which animal performance or behaviour has indicated that farm stray voltage may be affecting farm operations.

H.4.5 Investigation Sequence

An investigator shall carry out an investigation as follows:

Phase 1 Procedure

1. Animal Contact Test
2. Farm Stray Voltage Test

Phase 2 Procedure

1. Distributor Contribution Test
2. Distributor Contribution Calculations

Phase 3 Procedure

1. Distributor Contribution Confirmation Test & Calculations
2. Final Farm Stray Voltage Test

H.4.6 Documentation

The following documentation shall be prepared and retained by a distributor in accordance with 4.7.7 of the Code:

- (1) Sketch or line drawing of the farm on which are located, at a minimum:
 - a) Distribution transformer(s);
 - b) Distributor's phase and neutral conductors (indicating size and type);
 - c) Farm buildings;
 - d) Secondary electrical service panels;
 - e) Existing grounding electrodes;
 - f) Animal contact locations tested (using the identification numbers indicated on Form 1);
 - g) Remote reference ground rod used for testing purposes;
 - h) Primary and secondary neutral locations used in conjunction with the remote reference ground rod used for testing purposes;
 - i) Electric fences and other electrified animal control devices;
 - j) Water bowls; and

APPENDIX H

FARM STRAY VOLTAGE DISTRIBUTOR INVESTIGATION PROCEDURE

k) Well.

- (2) All information specified in the Forms set out in this Appendix. The Forms shall be in the format set out in this Appendix, and may be completed by hand or in electronic format.
- (3) All data recorded using digital recording devices, downloaded in electronic format.

H.4.7 Investigation Report

- (1) An investigator shall prepare a written report that complies with section H.4.7(2) and that sets out the results and findings of any investigation conducted under section 4.7 of the Code and this Appendix.
- (2) The written report shall contain, as a minimum, the following information: the name of the distributor; the name of the investigator; information on how and to whom inquiries about the investigation should be addressed; the date the livestock farm customer's complaint was received by the distributor; the date of the distributor's or investigator's initial site visit; the date the investigation was initiated; the date the investigation was concluded; a summary and explanation of the test results; and a brief description of any remediation measures taken or planned. Copies of all information specified in the Forms set out in this Appendix shall be attached to the report.
- (3) The distributor shall promptly provide a copy of the written report to the livestock farm customer. Electronic copies of recorded measurement data shall be made available to the livestock farm customer upon request.

H.5 INVESTIGATION PROCEDURE

This section H.5 refers to measurements for ACV. An investigator shall determine ACC on the basis of the ACV measurements using Ohm's Law (current = voltage/resistance).

H.5.1 Phase 1 Procedure

An investigator shall conduct the Phase 1 Procedure set out in and in accordance with sections H.5.1.1 and H.5.1.2 to determine whether the ACC/ACV Threshold is met.

H.5.1.1 Animal Contact Test

- (1) Purpose – The Animal Contact Test will identify the locations, if any, at which farm stray voltage may be present. Information collected in this test shall be used to determine the locations used for the Farm Stray Voltage Test.
- (2) Selection of Animal Contact Locations - Animal contact locations, including those where animal contact points can be contacted by low resistance body parts (e.g.

APPENDIX H

FARM STRAY VOLTAGE DISTRIBUTOR INVESTIGATION PROCEDURE

muzzle, hoof, and udder), shall be selected in consultation with the livestock farm customer.

- (3) Test Preparation - Where possible and with the permission of the livestock farm customer, turn off all farm loads with the exception of one consistent load (e.g. a hairdryer) in order to eliminate the potential impact of farm load variability on measurements taken at different animal contact locations.

(4) Animal Contact Point Preparation

- a) Where an animal contact point is the floor or earth surface, the measuring device shall be connected to a copper plate, which shall make a high quality conductive contact with the floor or earth surface. The floor or earth surface beneath and around the copper plate shall be clear of debris that may add excess resistance. If the floor is concrete, the copper plate shall be placed where the surface is flat and, if needed, cleaned using water and a wire brush.

For each animal contact location tested, calculated source resistance (R_{source}) should be 500 Ohms or less. If high quality conductive contact with the floor or earth cannot be made using the procedure described above, the following procedures shall be followed:

- Floor contact - Place a paper towel or similar material soaked in salt water solution between the copper plate and the floor. Place a weight of not less than ten kilograms on the plate. This weight shall be applied evenly across the plate and not to the adjacent concrete or earth. Place the plate a minimum distance of thirty centimetres or twelve inches from any metal equipment making contact with the floor or earth.
- Earth contact – Locate a flat surface, remove any debris and add water to the area to ensure sufficient dampness if necessary.

- b) Where an animal contact point involves a metal surface, corrosion shall be removed from the area where a test lead is used to contact the metal.

(5) Data Documented – For each animal contact location:

- a) Record the open circuit voltage (without a shunt resistor) between animal contact points: V_{oc}
- b) Record, within ten seconds of recording the open circuit voltage, the ACV between animal contact points with a five hundred Ohm nominal shunt resistor placed across the meter inputs: V_{cc}

APPENDIX H

FARM STRAY VOLTAGE DISTRIBUTOR INVESTIGATION PROCEDURE

c) Calculate and note the source resistance: R_{source}

(6) Data Records – An investigator shall record the results of and other information relating to the Animal Contact Test using Form 1 of this Appendix.

H.5.1.2 Farm Stray Voltage Test

(1) Purpose - The purpose of this test is to determine the highest level of farm stray voltage at the location(s) identified in the Animal Contact Test.

(2) Reference Ground Rod Setup - A portable ground rod shall be inserted 0.5 m into the earth, located as follows:

- at least 15 m (or 50 feet) from the ground rod under test;
- well away from any well casing present;
- not closer than 7.5 m (or 25 feet) from the centerline of a primary electrical conductor right-of-way;
- not closer than 30 m (or 100 feet) from the edge of a transmission line right-of-way; and
- when practicable, at least 7.5 m (or 25 feet) from the nearest underground conductive electrical equipment of any type and at a distance equal to three to four times the buried depth of any metallic structure connected to the service entrance neutral.

(3) Digital Recording Device Setup - A digital recording device shall be used to measure and record data in accordance with section H.5.1.2(6). The device shall be prepared as follows:

- connect one lead to the reference ground rod. Use a second wire to extend the other lead to the ground wire connecting the neutral to the ground rod at the service entrance serving the area under investigation.
- install a 10,000 Ohm resistor across the input leads and note the reading. Install a second 10,000 Ohm resistor (in series) across the input leads and note whether the reading decreases by more than 10%. Where the reading decreases by more than 10%, the reference ground rod shall be moved to another location to reduce the resistance. When a good connection to earth has been established, remove both resistors from the digital recording device.

(4) Selection of Animal Contact Locations - The animal contact location at which the highest animal contact voltage reading was measured in the Animal Contact Test shall be used for the purposes of this test. Additional animal contact locations may also be tested simultaneously.

APPENDIX H
FARM STRAY VOLTAGE DISTRIBUTOR INVESTIGATION PROCEDURE

- (5) Animal Contact Point Preparation – The procedure set out in section H.5.1.1(4) shall be applied.
- (6) Measurement Interval - The measurement interval over which true rms values are averaged during recording shall not exceed ten seconds.
- (7) Data Recorded -
- a) Voltage from the primary neutral at the transformer to the reference ground rod: V_p .
 - b) Voltage from the secondary neutral in the service panel serving the animal contact area (note: where a watering device is involved, the service panel to which the water line is bonded shall be used) to the reference ground rod: V_s
 - c) Voltage drop from the primary neutral conductor at the location of the connection for V_p to the secondary neutral conductor at the location of the connection for V_s : V_{ps}
 - d) Voltage across a five hundred Ohm resistor at the high ACV points as selected in accordance with section H.5.1.2(4): V_{cc}
- (8) Test Duration and Continuity – Data shall be recorded over a period of not less than forty-eight consecutive hours. The test shall be repeated unless data is recorded without interruption for a minimum of twenty-four consecutive hours. The test shall also be repeated if testing is interrupted for more than twenty minutes during any twelve hour period.
- (9) Data Records - An investigator shall record the results of and other information relating to the Farm Stray Voltage Test using Form 2 of this Appendix. A plot of the required measurements versus time may be substituted for or included with a completed Form 2. All recorded data shall be downloaded and retained with the other records of the investigation.
- (10) Interpretation – Compare the ACV (V_{cc}) values noted on Form 2 to the ACC/ACV Threshold. An investigator shall carry out the Phase 2 Procedure if the ACC/ACV Threshold is met. If the ACC/ACV Threshold is not met, the investigation shall be terminated.

APPENDIX H

FARM STRAY VOLTAGE DISTRIBUTOR INVESTIGATION PROCEDURE

H.5.2 Phase 2 Procedure

An investigator shall conduct the Phase 2 Procedure set out in and in accordance with sections H.5.2.1 and H.5.2.2 to determine whether the Distributor Contribution Threshold is met.

H.5.2.1 Distributor Contribution Test

- (1) Purpose - The Distributor Contribution Test is used to determine whether and the extent to which the distribution system contributes to farm stray voltage at animal contact locations.
- (2) Application – This test shall be carried out at each point where a livestock farm customer's farm is connected to the distribution system at a distribution transformer.
- (3) Time of Test - This test shall be performed at the same time of day as the times of highest ACV found in the Farm Stray Voltage Test.
- (4) Preparation - Before commencing the test, measure the secondary neutral current with the farm completely de-energized. The secondary neutral current should be very low. If the current is high, this indicates some 120 volt load is energized. Investigate and de-energize as required.
- (5) Data Documented
 - a) Eight data points shall be documented as follows:
 1. Note nominal primary phase conductor voltage to neutral conductor voltage: V_{pri}
 2. Measure load box current: I_{LB}
 3. Measure voltage at load box connection to secondary system: V_{LB} (~240V)
 4. Calculate transformer primary current (on the source side of the ground connection): I_p
 5. Measure animal contact voltage at the same points used in the Farm Stray Voltage Test (not shown on Figure 1): V_{cc}
 6. Measure voltage from primary neutral at the transformer to remote reference ground rod: V_p
 7. Measure voltage from secondary neutral in the service panel serving the area of the animal contact to remote reference ground rod: V_s
 8. Measure voltage from primary neutral at the transformer to secondary neutral at the service panel serving the area of animal contact: V_{ps}

APPENDIX H
FARM STRAY VOLTAGE DISTRIBUTOR INVESTIGATION PROCEDURE

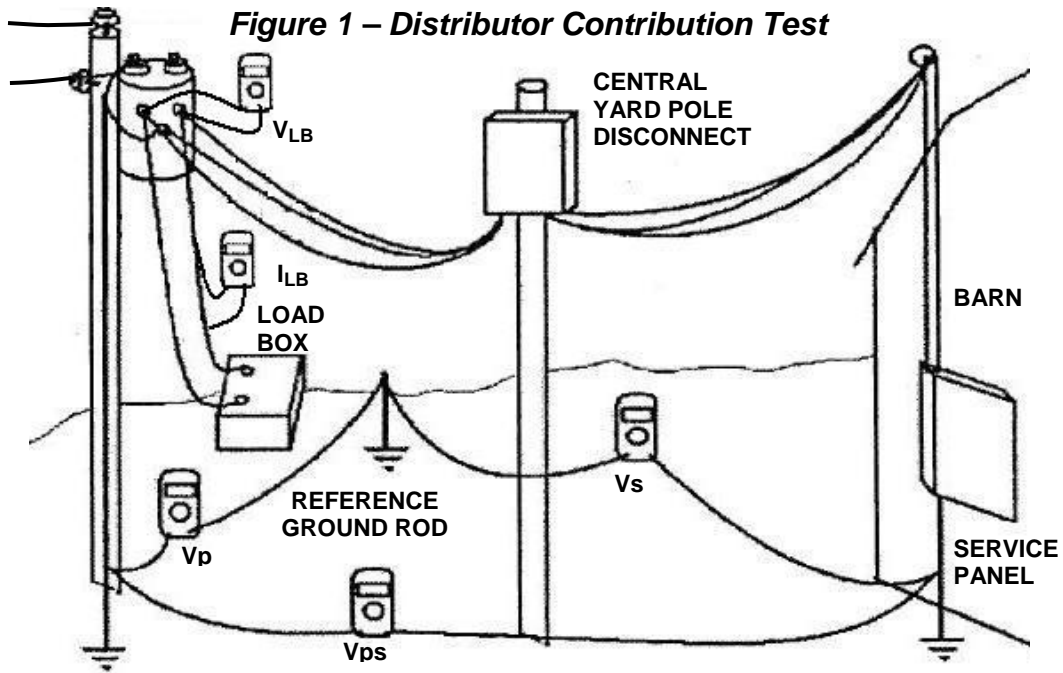

Figure 1 illustrates the measurement locations indicated above. Figure 2 illustrates the appropriate meter arrangement.

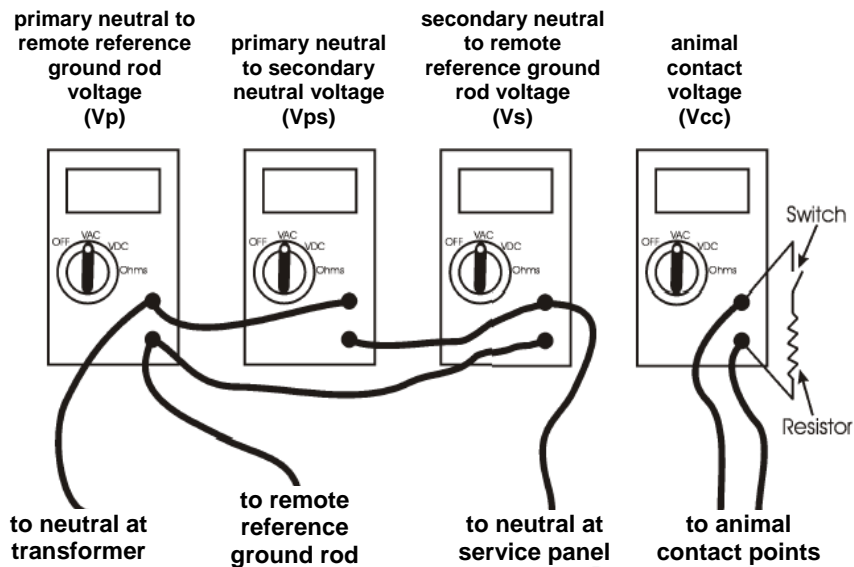

Figure 2 – Meter Arrangement for Distributor Contribution Test

- (6) Conducting the Test - Attach the load box to the 240 Volt secondary side of the transformer. For single phase services, conduct Steps 1 through 5 listed below. For three phase services, conduct Step 1 and Step 2 listed below for each

APPENDIX H
FARM STRAY VOLTAGE DISTRIBUTOR INVESTIGATION PROCEDURE

phase, or conduct Steps 1 through 5 listed below for one phase only. Each test must be conducted for at least two minutes, with the highest readings observed during the interval recorded on Form 3.

- a) Step 1: Load box de-energized; farm energized.
- b) Step 2: Load box de-energized; farm de-energized.
- c) Step 3: Load box energized at half load; farm de-energized.
- d) Step 4: Load box energized to full load; farm de-energized.
- e) Step 5: Load box energized to full load; farm energized.

(7) Data Records - An investigator shall record the results of and other information relating to the Distributor Contribution Test using Form 3 of this Appendix.

H.5.2.2 Distributor Contribution Calculations

(1) Purpose – The purpose of this procedure is to calculate the contribution of the distributor’s distribution system to farm stray voltage.

(2) Data Analysis

- a) Determine from the Farm Stray Voltage Test data the highest measured steady state value of ACV ($V_{CC_{fsv}}$) and the corresponding measured value for the primary neutral to reference ground rod voltage ($V_{p_{fsv}}$). Record these values on Form 4 at Step 1.
- b) The primary neutral to remote reference ground rod voltage ($V_{p_{off}}$) and the ACV ($V_{CC_{off}}$) measured during the Distributor Contribution Test with the farm power “off” and the load box “off” shall be recorded on Form 4 at Step 2.
- c) The primary neutral to remote reference ground voltage ($V_{p_{half}}$) and the animal contact voltage ($V_{CC_{half}}$) measured during the Distributor Contribution Test with the farm power “off” and the load box set at one-half (1/2) load shall be recorded on Form 4 at Step 3.
- d) The primary neutral to remote reference ground voltage ($V_{p_{full}}$) and the animal contact voltage ($V_{CC_{full}}$) measured during the Distributor Contribution Test with the farm power “off” and the load box set at maximum load shall be recorded on Form 4 at Step 4.

(3) For Single Phase Farms - The contribution of the distributor’s distribution system to ACV (V_{CCD}) shall be determined using the following formula:

$$V_{CCD} = \frac{V_{p_{fsv}} - V_{p_{half}}}{V_{p_{full}} - V_{p_{half}}} \times (V_{CC_{full}} - V_{CC_{half}}) + V_{CC_{half}}$$

APPENDIX H

FARM STRAY VOLTAGE DISTRIBUTOR INVESTIGATION PROCEDURE

- (4) For Three Phase Farms - The contribution of the distributor's distribution system to ACV (V_{ccD}) for farms with three phase balanced load service is the measured ACV recorded in Step 2 of the Distributor Contribution Test (see H.5.2.1(6); i.e. with the load box de-energized and the farm de-energized) and recorded on Form 4 as V_{ccOff} .
- (5) Interpretation – Compare the V_{ccD} value (from either (3) or (4) above as appropriate) to the Distributor Contribution Threshold.
- (6) Data Records – An investigator shall record the results of and other information relating to the distributor contribution calculations using Form 4 of this Appendix.

H.5.3 Phase 3 Procedure

Where the Distributor Contribution Threshold has been met, an investigator shall conduct the Phase 3 Procedure set out in and in accordance with sections H.5.3.1 and H.5.3.2 to confirm whether remediation activities taken by the distributor have resulted in the contribution of the distributor's distribution system to farm stray voltage decreasing to a level that is below the Distributor Contribution Threshold; and to determine the impact of distributor remediation activities on ACC/ACV.

H.5.3.1 Distributor Contribution Confirmation Test & Calculations

- (1) Purpose – The purpose of this procedure is to confirm whether the remediation activities carried out by a distributor have resulted in the contribution of the distributor's distribution system to farm stray voltage decreasing to a level that is below the Distributor Contribution Threshold.
- (2) Procedure - The investigator shall repeat the Distributor Contribution Test and shall for that purpose make measurements at the same locations as used for the original Distributor Contribution Test. The investigator shall repeat the distributor contribution calculations in accordance with section H.5.2.2.
- (3) Data Records - An investigator shall record the results of and other information relating to the distributor contribution confirmation test and calculations using Form 5 of this Appendix.

H.5.3.2 Final Farm Stray Voltage Test

- (1) Purpose – The purpose of this test is to determine the impact of a distributor's remediation activities on farm stray voltage.

APPENDIX H
FARM STRAY VOLTAGE DISTRIBUTOR INVESTIGATION PROCEDURE

- (2) Procedure - An investigator shall repeat the Farm Stray Voltage Test, other than in relation to section H.5.1.2(10), and shall for that purpose make measurements at the same animal contact locations used for purposes of the original Farm Stray Voltage Test.

- (3) Data Records - An investigator shall record the results of and other information relating to the final Farm Stray Voltage Test using Form 6 of this Appendix. A plot of the required measurements versus time may be substituted for or included with a completed Form 6. All recorded data shall be downloaded and retained with the records of the investigation.

APPENDIX H
FARM STRAY VOLTAGE DISTRIBUTOR INVESTIGATION PROCEDURE

FORMS

APPENDIX H
FARM STRAY VOLTAGE DISTRIBUTOR INVESTIGATION PROCEDURE

FORM 1

ANIMAL CONTACT TEST

Customer Name: _____ Date: _____
Farm Location: _____ File No: (if applicable): _____

INSTRUCTIONS

1. The information provided by the Animal Contact Location Identification Number, and corresponding description, and by the farm sketch(es) shall be sufficient to allow a third party to locate the animal contact locations and identify the animal contact points noted on the Animal Contact Test Data Record.
2. Voltage measurements shall be made using one instrument to ensure consistency. The second measurement required for each animal contact location shall be taken immediately after the first measurement has been recorded. Comments related to the measurement process shall be recorded on the Animal Contact Test Comments sheet.
3. Calculate R_{source} as follows:

$$R_{\text{source}} = \frac{V_{\text{OC}} - V_{\text{CC}}}{V_{\text{CC}}} \times R_{\text{shunt}}$$

where $R_{\text{shunt}} = 500 \text{ Ohms}$

4. R_{source} should be less than 500 Ohms, ideally closer to 250 Ohms. Where R_{source} is greater than 500 Ohms, clean animal contact points and add salt water solution to the contact area.

**APPENDIX H
FARM STRAY VOLTAGE DISTRIBUTOR INVESTIGATION PROCEDURE**

FORM 1 (continued)

ANIMAL CONTACT TEST DATA RECORD

Animal Contact Location ID #	Description of Location & Animal Contact Points	Voltage w/o Shunt Resistor	Voltage w/Shunt Resistor	Source Resistance
		V_{oc}	V_{cc}	R_{source}
1				
2				
3				
4				
5				
6				
7				
8				
9				
10				

**APPENDIX H
FARM STRAY VOLTAGE DISTRIBUTOR INVESTIGATION PROCEDURE**

Animal Contact Location ID #	Description of Location & Animal Contact Points	Voltage w/o Shunt Resistor	Voltage w/Shunt Resistor	Source Resistance
		V_{oc}	V_{cc}	R_{source}
11				
12				
13				
14				
15				
16				
17				
18				
19				
20				

**APPENDIX H
FARM STRAY VOLTAGE DISTRIBUTOR INVESTIGATION PROCEDURE**

**FORM 1 (concluded)
ANIMAL CONTACT TEST COMMENTS**

Animal Contact Location ID #	Comment
1	
2	
3	
4	
5	
6	
7	
8	
9	
10	

APPENDIX H
FARM STRAY VOLTAGE DISTRIBUTOR INVESTIGATION PROCEDURE

Animal Contact Location ID #	Comment
11	
12	
13	
14	
15	
16	
17	
18	
19	
20	

APPENDIX H
FARM STRAY VOLTAGE DISTRIBUTOR INVESTIGATION PROCEDURE

FORM 2

FARM STRAY VOLTAGE TEST

Customer Name: _____ Date: _____

Farm Location: _____ File No: (if applicable): _____

Start Date/Time: _____ Stop Date/Time: _____

Animal Contact Location Identification No: _____

FARM STRAY VOLTAGE TEST DATA

Hour	Time Highest Steady State Vcc Recorded in Hour Hour:Min	Readings at the time (Hour:Min) noted at left:				Estimated Time During Hour Vcc Exceeds ACC/ACV Threshold Min
		Animal Contact Voltage Across Shunt Resistor Vcc	Primary Neutral to Reference Ground Rod Voltage Vp	Secondary Neutral to Reference Ground Rod Voltage Vs	Primary Neutral to Secondary Neutral Voltage Vps	
1						
2						
3						
4						
5						
6						
7						
8						
9						
10						
11						
12						
13						
14						
15						
16						
17						
18						
19						
20						
21						
22						
23						
24						
25						

APPENDIX H
FARM STRAY VOLTAGE DISTRIBUTOR INVESTIGATION PROCEDURE

Hour	Time Highest Steady State Vcc Recorded in Hour Hour:Min	Readings at the time (Hour:Min) noted at left:				Estimated Time During Hour Vcc Exceeds ACC/ACV Threshold Min
		Animal Contact Voltage Across Shunt Resistor Vcc	Primary Neutral to Reference Ground Rod Voltage Vp	Secondary Neutral to Reference Ground Rod Voltage Vs	Primary Neutral to Secondary Neutral Voltage Vps	
26						
27						
28						
29						
30						
31						
32						
33						
34						
35						
36						
37						
38						
39						
40						
41						
42						
43						
44						
45						
46						
47						
48						
49						
50						
51						
52						
53						
54						
55						
56						
57						
58						
59						
60						

APPENDIX H
FARM STRAY VOLTAGE DISTRIBUTOR INVESTIGATION PROCEDURE

Hour	Time Highest Steady State Vcc Recorded in Hour	Readings at the time (Hour:Min) noted at left:				Estimated Time During Hour Vcc Exceeds ACC/ACV Threshold
		Animal Contact Voltage Across Shunt Resistor	Primary Neutral to Reference Ground Rod Voltage	Secondary Neutral to Reference Ground Rod Voltage	Primary Neutral to Secondary Neutral Voltage	
	Hour:Min	Vcc	Vp	Vs	Vps	Min
61						
62						
63						
64						
65						
66						
67						
68						
69						
70						
71						
72						

APPENDIX H
FARM STRAY VOLTAGE DISTRIBUTOR INVESTIGATION PROCEDURE

FORM 3

DISTRIBUTOR CONTRIBUTION TEST DATA

Customer Name: _____ Date: _____
 Farm Location: _____ File No: (if applicable): _____

1. Initial measurements and calculations with farm service de-energized:

Primary Nominal Voltage Phase to Neutral (V_{pri}): _____ V (e.g. 8kV)

Load Box Current (I_{LB}): Half Load _____ A Full Load _____ A

Load Box Voltage (V_{LB}): Half Load _____ V Full Load _____ V

Transformer Primary Current (I_p): _____

where:

$$I_p = \frac{I_{LB} \times V_{LB}}{V_{pri}}$$

Note: I_p is measured on the source side of the ground connection.

2. Distributor Contribution Test Measurements

		Step 1	Step 2	Step 3	Step 4	Step 5
Setting	Farm	ON	OFF	OFF	OFF	ON
	Load Box	OFF	OFF	HALF	FULL	FULL
Enter Start Time:						
Item		Record Highest Value Measured Over Minimum 2 minute Test Duration				
V _{cc} (V)						
V _p (V)						
V _s (V)						
V _{ps} (V)						

APPENDIX H
FARM STRAY VOLTAGE DISTRIBUTOR INVESTIGATION PROCEDURE

FORM 3 (concluded)

NOTE ON DISTRIBUTOR CONTRIBUTION TEST

1. With all farm power disconnected, there are no sources for neutral-to-earth voltage to be produced on the farm. The voltages measured at all locations should be approximately the same (FARM OFF, LOAD BOX OFF). There may be a difference of a few tenths of a volt in some situations. Assuming the primary (distributor) and secondary (farm) neutral conductors are bonded at the transformer, any voltage measured with the farm power off is most likely due to an off-farm source. The source may be voltage drop on the primary neutral, or it can be a ground fault at a neighbouring property in the area.
2. If a farm is supplied with a single-phase multi-grounded utility distribution line, the 240 volt load test should result in at least a slight increase in voltage when the load is applied (Farm OFF, Load Box FULL). A large increase in neutral-to-earth voltage during the 240 volt load test indicates the primary neutral circuit resistance may need to be reduced.

APPENDIX H
FARM STRAY VOLTAGE DISTRIBUTOR INVESTIGATION PROCEDURE

FORM 4

DISTRIBUTOR CONTRIBUTION CALCULATION

Customer Name: _____ Date: _____

Farm Location: _____ File No: (if applicable): _____

Farm Service Type: Three Phase Single Phase

Step 1: Enter the highest value of animal contact voltage recorded during the Farm Stray Voltage test on Form 2 ($V_{CC_{fsv}}$) and the corresponding primary to reference ground voltage ($V_{p_{fsv}}$).

$V_{CC_{fsv}}$: _____ V $V_{p_{fsv}}$: _____ V

Step 2: Enter the value of animal contact voltage and corresponding primary to reference ground voltage that was present during the Distributor Contribution Test with the farm power off and the load box off.

$V_{CC_{off}}$: _____ V $V_{p_{off}}$: _____ V

Step 3: Enter the value of animal contact voltage and corresponding primary to reference ground voltage that was present during the Distributor Contribution Test with the farm power off and the load box set at half load.

$V_{CC_{half}}$: _____ V $V_{p_{half}}$: _____ V

Step 4: Enter the value of animal contact voltage and corresponding primary to reference ground voltage that was present during the Distributor Contribution Test with the farm power off and the load box set at maximum load.

$V_{CC_{full}}$: _____ V $V_{p_{full}}$: _____ V

Distributor Contribution to ACC/ACV (V_{CCD})

Calculated V_{CCD} for farms with single phase service: _____ V

$$V_{CCD} = \frac{V_{p_{fsv}} - V_{p_{half}}}{V_{p_{full}} - V_{p_{half}}} \times (V_{CC_{full}} - V_{CC_{half}}) + V_{CC_{half}}$$

Measured V_{CCD} ($V_{CCD} = V_{CC_{off}}$) for farms with three phase service: _____ V

APPENDIX H
FARM STRAY VOLTAGE DISTRIBUTOR INVESTIGATION PROCEDURE

FORM 5
DISTRIBUTOR CONTRIBUTION CONFIRMATION TEST AND CALCULATIONS
Test Data

Customer Name: _____ Date: _____
 Farm Location: _____ File No: (if applicable): _____

1. Initial measurements and calculations with farm service de-energized:

Primary Nominal Voltage Phase to Neutral (V_{pri}): _____ V (e.g. 8kV)

Load Box Current (I_{LB}): Half Load _____ A Full Load _____ A

Load Box Voltage (V_{LB}): Half Load _____ V Full Load _____ V

Transformer Primary Current (I_p): _____

where:

$$I_p = \frac{I_{LB} \times V_{LB}}{V_{pri}}$$

Note: I_p is measured on the source side of the ground connection.

2. Load box measurements

		Step 1	Step 2	Step 3	Step 4	Step 5
Setting	Farm	ON	OFF	OFF	OFF	ON
	Load Box	OFF	OFF	HALF	FULL	FULL
Enter Start Time:						
Item		Record Highest Value Measured Over Minimum 2 minute Test Duration				
V _{cc} (V)						
V _p (V)						
V _s (V)						
V _{ps} (V)						

APPENDIX H
FARM STRAY VOLTAGE DISTRIBUTOR INVESTIGATION PROCEDURE

FORM 5 (concluded)
DISTRIBUTOR CONTRIBUTION CONFIRMATION TEST AND CALCULATIONS
Calculations

Customer Name: _____ Date: _____
Farm Location: _____ File No: (if applicable): _____
Farm Service Type: Three Phase Single Phase

Step 1: Enter the highest value of animal contact voltage recorded during the Farm Stray Voltage Test on Form 2 ($V_{CC_{fsv}}$) and the corresponding primary to reference ground voltage ($V_{p_{fsv}}$).

$V_{CC_{fsv}}$: _____ V $V_{p_{fsv}}$: _____ V

Step 2: Enter the value of animal contact voltage and corresponding primary to reference ground voltage that was present during the Distributor Contribution Test with the farm power off and the load box off.

$V_{CC_{off}}$: _____ V $V_{p_{off}}$: _____ V

Step 3: Enter the value of animal contact voltage and corresponding primary to reference ground voltage that was present during the Distributor Contribution Test with the farm power off and the load box set at half load.

$V_{CC_{half}}$: _____ V $V_{p_{half}}$: _____ V

Step 4: Enter the value of animal contact voltage and corresponding primary to reference ground voltage that was present during the Distributor Contribution Test with the farm power off and the load box set at maximum load.

$V_{CC_{full}}$: _____ V $V_{p_{full}}$: _____ V

Distributor Contribution to ACC/ACV (V_{CCD})

Calculated V_{CCD} for farms with single phase service: _____ V

$$V_{CCD} = \frac{V_{p_{fsv}} - V_{p_{half}}}{V_{p_{full}} - V_{p_{half}}} \times (V_{CC_{full}} - V_{CC_{half}}) + V_{CC_{half}}$$

Measured V_{CCD} ($V_{CCD} = V_{CC_{off}}$) for farms with three phase service: _____ V

**APPENDIX H
FARM STRAY VOLTAGE DISTRIBUTOR INVESTIGATION PROCEDURE**

FORM 6

FINAL FARM STRAY VOLTAGE TEST

Customer Name: _____ Date: _____

Farm Location: _____ File No: (if applicable): _____

Start Date/Time: _____ Stop Date/Time: _____

Animal Contact Location Identification No: _____

FINAL FARM STRAY VOLTAGE TEST DATA

Hour	Time Highest Steady State Vcc Recorded in Hour Hour:Min	Readings at the time (Hour:Min) noted at left:				Estimated Time During Hour Vcc Exceeds ACC/ACV Threshold Min
		Animal Contact Voltage Across Shunt Resistor Vcc	Primary Neutral to Reference Ground Rod Voltage Vp	Secondary Neutral to Reference Ground Rod Voltage Vs	Primary Neutral to Secondary Neutral Voltage Vps	
1						
2						
3						
4						
5						
6						
7						
8						
9						
10						
11						
12						
13						
14						
15						
16						
17						
18						
19						
20						
21						
22						
23						
24						
25						

APPENDIX H
FARM STRAY VOLTAGE DISTRIBUTOR INVESTIGATION PROCEDURE

Hour	Time Highest Steady State Vcc Recorded in Hour Hour:Min	Readings at the time (Hour:Min) noted at left:				Estimated Time During Hour Vcc Exceeds ACC/ACV Threshold Min
		Animal Contact Voltage Across Shunt Resistor Vcc	Primary Neutral to Reference Ground Rod Voltage Vp	Secondary Neutral to Reference Ground Rod Voltage Vs	Primary Neutral to Secondary Neutral Voltage Vps	
26						
27						
28						
29						
30						
31						
32						
33						
34						
35						
36						
37						
38						
39						
40						
41						
42						
43						
44						
45						
46						
47						
48						
49						
50						
51						
52						
53						
54						
55						
56						
57						
58						
59						
60						

APPENDIX H
FARM STRAY VOLTAGE DISTRIBUTOR INVESTIGATION PROCEDURE

Hour	Time Highest Steady State Vcc Recorded in Hour	Readings at the time (Hour:Min) noted at left:				Estimated Time During Hour Vcc Exceeds ACC/ACV Threshold
		Animal Contact Voltage Across Shunt Resistor	Primary Neutral to Reference Ground Rod Voltage	Secondary Neutral to Reference Ground Rod Voltage	Primary Neutral to Secondary Neutral Voltage	
	Hour:Min	Vcc	Vp	Vs	Vps	Min
61						
62						
63						
64						
65						
66						
67						
68						
69						
70						
71						
72						